

D. H. CHURCH.
UPRIGHTING LATHE.

No. 486,609.

Patented Nov. 22, 1892.

FIG. 1.

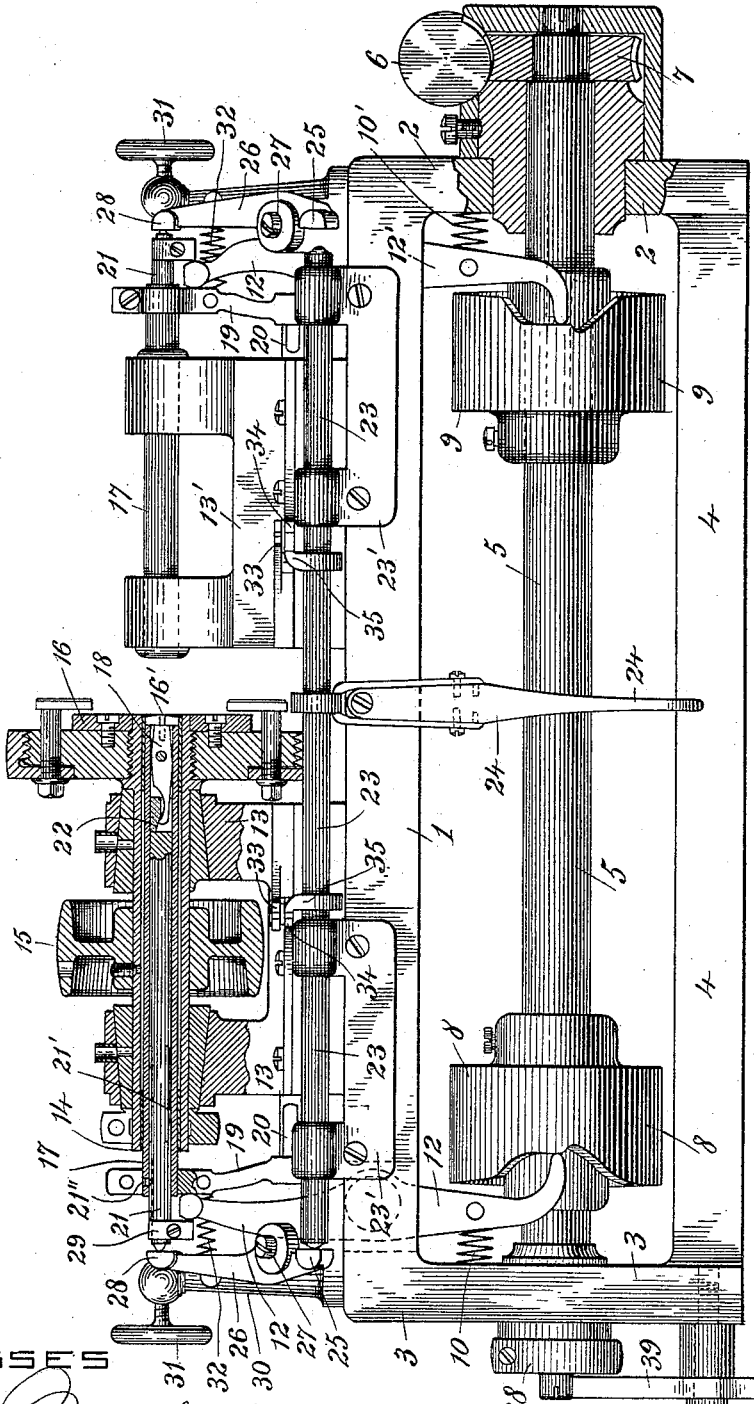

WITNESSES

R. H. Marsh.
A. D. Harrison.

INVENTOR.

D. H. Church
 by *Wm. H. Corsey*
Atty.

D. H. CHURCH.
UPRIGHTING LATHE.

No. 486,609.

Patented Nov. 22, 1892.

FIG. 2.

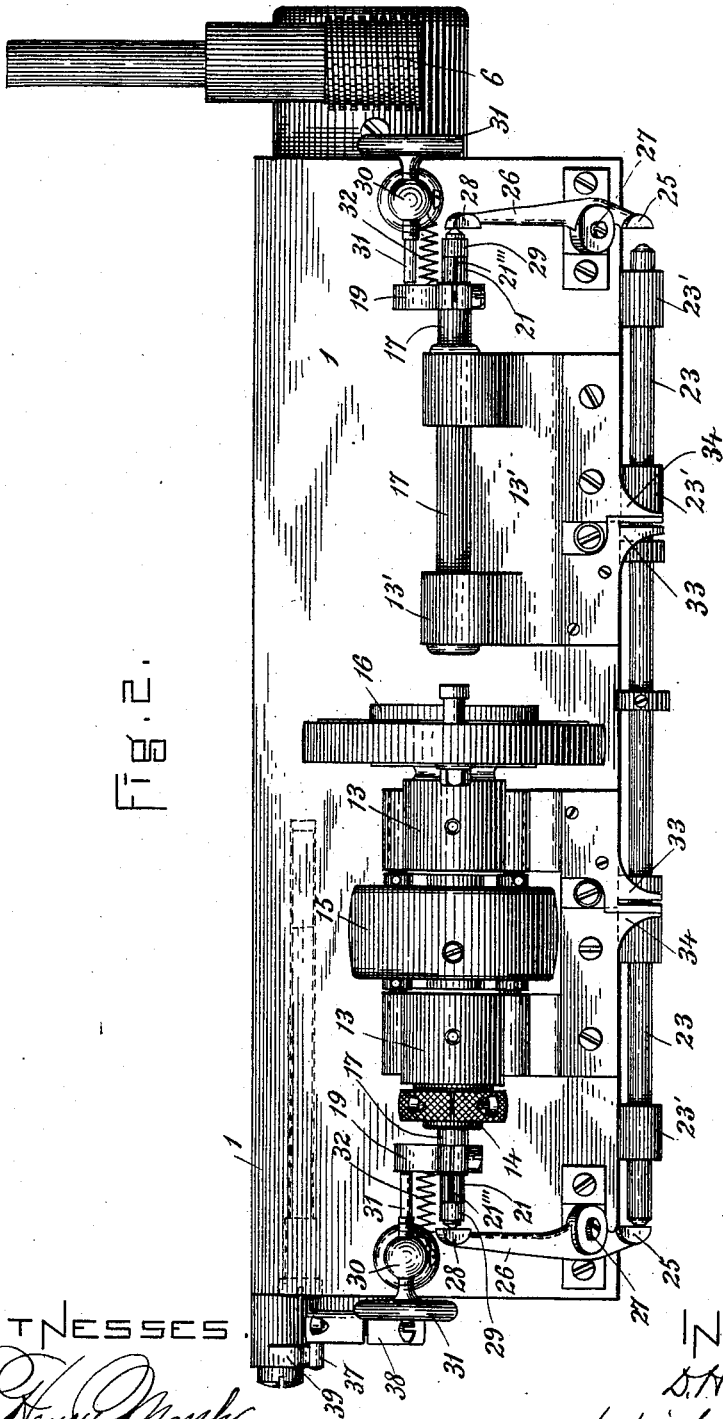

WITNESSES.

R. H. Marsh.
A. D. Harrison.

INVENTOR

D. H. Church
 by *Wm. B. Forsyth*
Atty

D. H. CHURCH.
UPRIGHTING LATHE.

No. 486,609.

Patented Nov. 22, 1892.

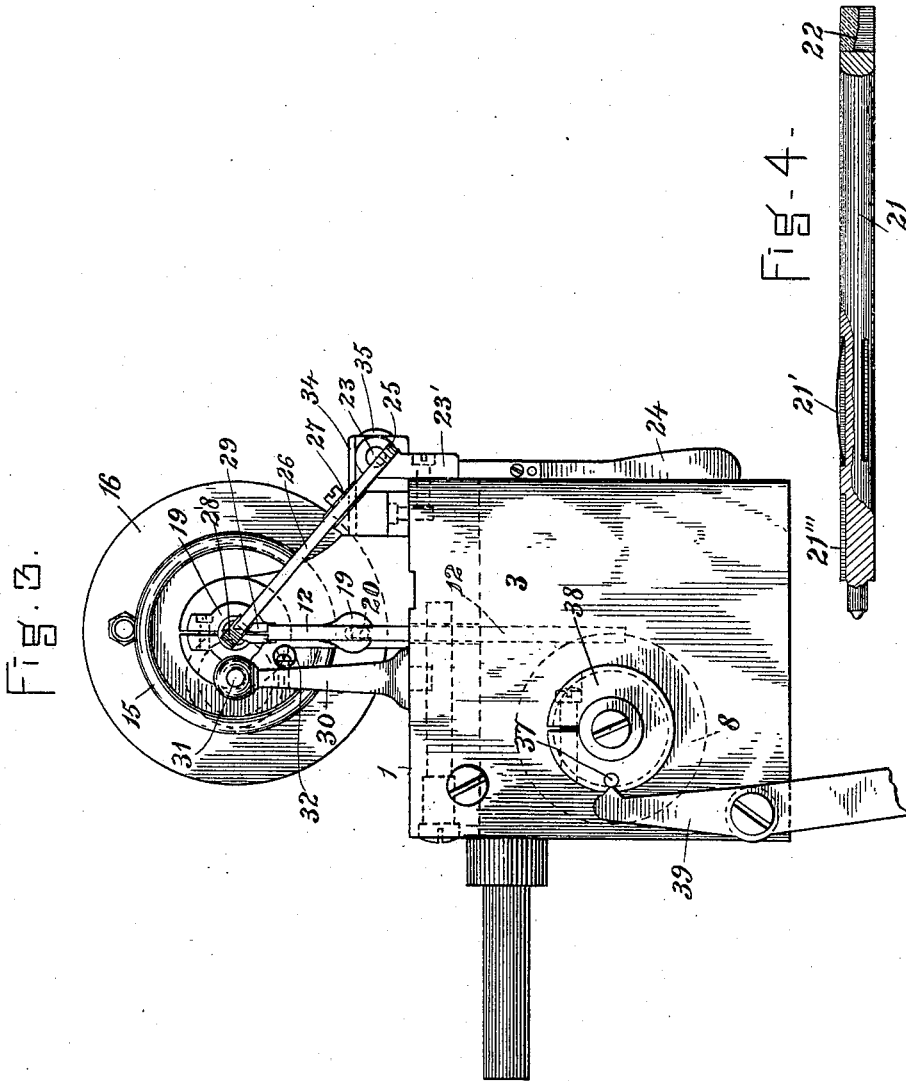

WITNESSES.

R. Henry March.
A. D. Henison.

INVENTOR.

D. H. Church
by *Night Brown Corsey*
Atty

UNITED STATES PATENT OFFICE.

DUANE H. CHURCH, OF WALTHAM, MASSACHUSETTS.

UPRIGHTING-LATHE.

SPECIFICATION forming part of Letters Patent No. 486,609, dated November 22, 1892.

Application filed March 1, 1892. Serial No. 423,412. (No model.)

To all whom it may concern:

Be it known that I, DUANE H. CHURCH, of Waltham, in the county of Middlesex and State of Massachusetts, have invented certain new and useful Improvements in Uprighting-Lathes, of which the following is a specification.

The object of this invention is to produce a means for drilling the pivot-holes in the frame work of watches for the pivots of the respective shafts, to so perform the work as to insure the uprightness of the axis of the pivots and bring the holes on each side of the frame in exact alignment, to provide a caliper device for gaging the size of the pivot-holes to correspond with the respective shafts for which they are intended, and also to provide a means for boring the holes for one shaft in both sides of the frame at the same time, said holes being of a size to exactly fit the pivots of said shaft.

The invention consists in certain features of novelty more particularly pointed out in the claims, being first described with reference to the accompanying drawings, in which—

Figure 1 is a front elevation, partly in section, of a machine constructed according to my invention. Fig. 2 is a plan view of the same. Fig. 3 is an end elevation. Fig. 4 is detail of the tool-adjusting rod, showing the springs which hold it by frictional contact within the tool-carrying sleeve.

The machine consists of a frame constituting the bed 1, legs 2 3, and base 4. Mounted in this frame beneath the bed 1, journaled in the legs 2 3, is the main shaft 5, deriving its motion through worm 6 and gear 7, Fig. 1. This shaft carries the cams 8 9, which operate to feed the cutting-tools to their work through the medium of levers 12 12', having their fulcrum in the bed 1 of the frame. Interposed between the legs 2 3 and levers 12 12' are springs 10 10', which act in opposition to cams 8 9 and return levers 12 12' to position when released by said cams.

Supported on the bed 1 to the left is a standard 13, carrying a hollow live-spindle 14, to which rotary motion is imparted by pulley 15. At the extreme right or inner end the spindle 14 is provided with a face-plate 16, adapted to receive and hold the work to be operated upon. Within the spindle 14 is a tubular cutter-

holding spindle 17, which carries at one end the tool-holder 18. At the other end the cutter-holding spindle 17 is provided with a sliding dog 19, which holds it from partaking of the rotary motion of the spindle 14, but allows free longitudinal movement within said spindle 14 by reason of the dog 19 sliding upon a pin 20, projecting from the standard 13. Within the cutter-holding spindle 17 is placed the tool-operating rod 21, formed on its inner end with an inclined face 22, which by a longitudinal movement of said rod 21 acts upon the rear of the tool-holder 18 to throw the tool 16' more or less out of the axial line of spindle 14, according to the size of hole it is desired to make. This longitudinal movement of rod 21 is accomplished by sliding bar 23, operating through hand-lever 24 upon the lower end 25 of lever 26, fulcrumed at 27, the upper end 28 of which acts upon said rod 21 to thrust it inward. When thrust into place, the rod 21 is held by springs 21', which expand against the cutter-holding spindle 17 and act to hold said rod to any position it may be set by lever 26. (See Fig. 4.) Rod 21 is held from rotating within the cutter-holding spindle 17 and allowed free longitudinal movement by pin 21'' and slot 21''' . Rod 21 is withdrawn from cutter-holding spindle 17 by lever 12 operating upon collar 29.

Supported by bed 1 is a post 30, carrying an adjustable stop-screw 31, which limits (by contact with the dog 19) the withdrawal of the tool-carrying cutter-holding spindle 17, which is withdrawn by spring 32 when released by lever 12.

Projecting from standard 13 is a slotted plate 33 for receiving and supporting the shaft for which the hole is to be bored in the framework of the watch, while the caliper device is setting the tool 16' to position for cutting the hole of the proper size.

The caliper device consists of a stationary and a movable jaw, the stationary jaw 34 projecting from standard 13 directly under and in line, or nearly so, with the slotted plate 33. The movable jaw 35 of the caliper is carried by the sliding rod 23, which is supported in brackets 23', attached to the bed 1.

The standard 13' and other parts supported by the bed 1 to the right of the machine are

exact duplicates and operate in exactly the same manner as those above described, the hollow spindle 14 and its necessary parts being removed, as they operate only for holding and rotating the work. Similar reference-letters have consequently been placed upon the corresponding parts to the right of the machine, there being no description necessary.

Any suitable shipping device may be employed for stopping the machine between the successive operations, such as a pin 37 on collar 38, operating to trip lever 39 for shifting the belt.

The operation of the machine is as follows: The framework of the watch is clamped to the face-plate 16. The shaft for which the holes are to be drilled is first placed in the plate 33 to the left of the machine, bringing the pivot in line to be operated upon by the calipers. The operator then moves bar 23 to the left and clamps the pivot between the jaws 34 35 of the calipers. This movement of bar 23 operates lever 26 and thrusts in rod 21, which adjusts tool 16' to a position more or less eccentric to the axial line of the spindle 14, according to the diameter of the pivot in the calipers. This adjustment places the tool 16' in a position for cutting a hole of exactly the size corresponding to the pivot in the calipers, and springs 21' hold rod 21 in the position set by the pivot. The operator now removes the shaft from the calipers, reverses it, and places the pivot at the opposite end in the plate 33 at the right of the machine, which brings the pivot in line to be operated on by the calipers at the right of the machine. Bar 23 is now moved to the right and the jaws 34 35 to the right clamp the pivot, and the tool to the right of the machine is adjusted to proper place in the same manner as was tool 16'. The tools are now in proper position for cutting the holes for the pivots of this particular shaft. The machine is now put in motion. Pulley 15 revolves spindle 14 and face-plate 16, which is carrying the work to be operated upon. Worm and gear 6 7 rotate shaft 5 and cause cams 8 9 to slowly feed the tool-carrying cutter-holding spindle 17 inward through the medium of levers 12 12', and the holes are bored in the framework clamped on the face-plate 16. When the main shaft 5 has turned about one-half a revolution, the cutting-tools have completed their work and the lower ends of the levers 12 12' are resting upon the highest part of the cams 8 9, and from this point as the shaft 5 continues to turn the cams 8 9 release the levers 12 12' and allow springs 10 10' to act to return said levers to first position, which takes place when the shaft 5 has completed the revolution. This return of levers 12 12' releases the tool-carrying cutter-holding spindle 17 and allows

springs 32 to withdraw said sleeves until the dogs 19 come in contact with stop-screws 31, at which point the drilling-tools reach first position, and the machine is ready to repeat the operation. At this point pin 37, carried by collar 38 on main shaft 5, trips lever 39 and shifts the driving-belt to stop the machine for enabling the operator to remove or adjust the work on the face-plate.

I believe it to be new in uprighting-lathes to provide a hollow spindle with a cutter movable laterally within the spindle and means located within the spindle for controlling the lateral position of said spindle, and thereby causing it to cut a hole of any desired size, the size of the hole depending upon the distance to which the cutter is adjusted from the axial line of the spindle. Hence I do not limit myself to the means here shown for adjusting the cutter-holder laterally.

I claim—

1. In an uprighting-lathe, the combination of two cutter-holding spindles located in line with and facing each other and provided with laterally-adjustable cutters at their adjacent ends, means for moving said spindles simultaneously endwise in opposite directions, and a live-spindle inclosing one of said cutter-holding spindles and provided with a work-holder adapted to hold and rotate a piece of work between said cutters, as set forth.

2. In an uprighting-lathe, the combination of a cutter-holding spindle provided at one end with a laterally-adjustable cutter, means for moving said spindle endwise to present its cutter to a piece of work, and a rotating hollow spindle inclosing the cutter-holding spindle and provided with a work-holder arranged to hold and rotate the work in position to receive the action of the cutter, as set forth.

3. In an uprighting-lathe, the combination, with a rotary hollow spindle, of a cutter-holding spindle located within said spindle and provided with a laterally-movable cutter-holder, means for moving said cutter-holding spindle lengthwise of the rotary spindle, an adjusting device engaged with the cutter-holder and adapted to move the same laterally to vary its position relatively to the axial line of the rotary spindle, a caliper device, and connections between it and the adjusting device whereby the cutter may be adjusted, as set forth.

In testimony whereof I have signed my name to this specification, in the presence of two subscribing witnesses, this 31st day of October, A. D. 1891.

DUANE H. CHURCH.

Witnesses:

E. A. MARSH,
A. D. HARRISON.